



Innovative Multibeam Technology

Manufactured by



DISCOVER MORE WITH WASSP

WASSP is a great tool to explore the oceans, discover new diving locations, find wrecks and safely navigate uncharted waters



SEA MORE - DISCOVER MORE - FIND MORE - MAP MORE



Innovative Multibeam Technology



WASSP delivers unparalleled 120° high resolution coverage

WASSP incorporates the latest in multibeam technology, enabling you to very quickly profile the seafloor to find locations of interest. With a stabilised 120° swath coverage, WASSP generates 112 beams. Along each beam WASSP calculates the seafloor depth, seafloor characterisation or hardness, and also tracks any fish or water column targets.

With WASSP multibeam technology, your understanding of the marine environment will be greatly improved. High resolution 2D & 3D bathymetric seafloor profiles can be quickly created, enabling you to find and visualise areas of interest.

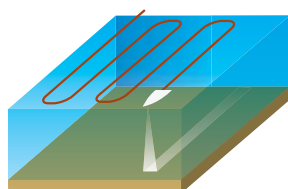

Conventional (10°) single beam sonar.

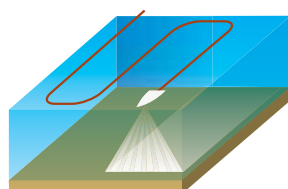

WASSP Multibeam sonar (120°) high resolution coverage.

With WASSP ,

- One pass over a ship wreck will enable you to profile a ship wreck and view in 3D.
- You can quickly profile a reef or potential Dive site, view in 3D and overlay fish shoal information over the reef.
- You can discover new fishing locations and overlay the fish shoals over the seafloor structure to better understand how to fish these new grounds.
- You can discover ship wrecks and find missing objects.
- You can build your own bathymetry profile of passageways, channels and bays not visited before, enabling you to more safely operate your vessel.

WASSP Seafloor profiles can be overlaid and viewed in both a processed and raw state. Importantly, WASSP bathymetry information can be overlaid over a Navionics® Gold Worldwide chart database. This enables you to build very detailed bathymetry information of interest to you.

MAP MORE

WASSP multibeam technology can generate over 700 depth points per second. Each point is stabilised, tide corrected, and seafloor hardness characterised enabling users to very quickly build high resolution bathymetric profiles of the marine environment. Importantly WASSP also profiles all fish and water column targets building the true picture – Hardness + profile + fish targets into a realtime 3D display.

MORE DEPTH

WASSP multibeam sonars are packed with features to enable you to better understand the marine environment. There are two frequency options available 160kHz or 80kHz depending upon the depth performance required. WASSP can profile from 1 metre to over 500 metres which meets most applications. Talk to your WASSP agent about which frequency will best suit your needs.

MORE EASE

WASSP customers – from fishermen and marine scientists to surveyors- report how easy WASSP is to use. A computer-mouse controls all functions and a user-friendly split-screen Windows System allows you to optimise the displays to suit your particular requirements. WASSP hardware is designed and manufactured to ISO9001-2008 standards.

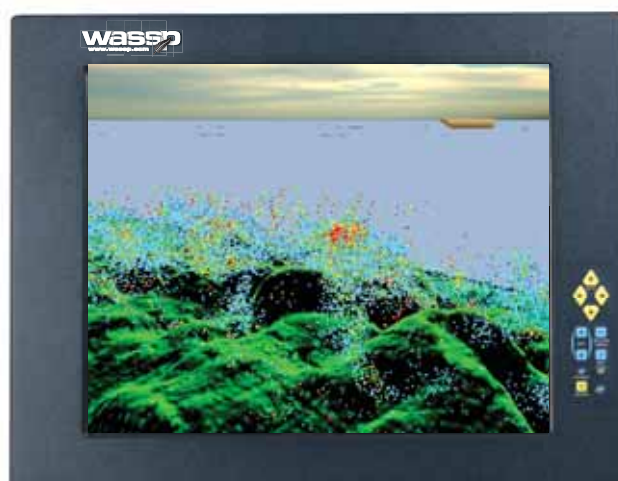

3D view of reef plus fish in the water column.



SEA MORE WITH WASSP NAVIGATOR.

WASSP Navigator will enable you to build and save very detailed bathymetric profiles, to record fish shoal information and to share this information with other WASSP users or vessels. Navigator is a management tool to enable you to highlight, profile, view in any direction – 2D or 3D, save and print information you collect about the marine environment

Explorer – Unique to WASSP

Explorer is a set of unique software and hardware designed to add extra benefits to Super Yacht Exploration and Charter activities. Yacht Skippers are being asked to operate in waters with only limited Navigation information. Now with WASSP and Explorer, Skippers can send a Tender Vessel out to explore and build their own Bathymetric seafloor profiles ahead of the “Mother Vessel”. 120° Bathymetric profiles can be transmitted back to the Mother vessel providing realtime information on the WASSP “ECS” – electronic chart system display. The location of the Mother Vessel and 2nd Tender Vessel are displayed along with the Bathymetric profiles transmitted from the WASSP .

There are three methods to transfer Bathymetric data from Tender to Mother Vessel.

1. Via UHF radio link – Benefit, long line of sight distance (up to 10nm) from tender to Mother vessel. Data limited in resolution.
2. Via WAN to link Tender to Mother Vessel – Benefit, higher data rate = greater resolution from Wasp, range limited to 3nm.
3. By recording information on the tender and updating the Mother Vessel Navigator display via USB storage drive. Benefit – full detail can be transferred, data not real time.

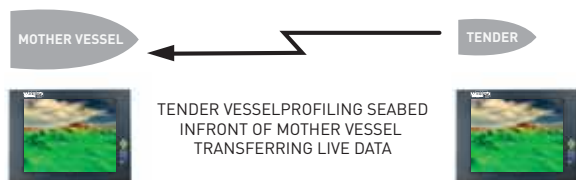

ON THE SUPER YACHT.

On the bridge of the Super Yacht will be a Nav PC running WASSP Navigator. This is a simple ECS display that can be easily operated via touch screen or mouse. The Navigator display is designed to manage your WASSP bathymetry data and water column data. It will also show and track the Tender out collecting bathymetry data. The Navigator display can be used as an aid to planning Navigation routes through confined water ways, to plan future dive expeditions and review data collected via WASSP Multibeam sonar. The Navigator can be connected either to a serial port and UHF modem, or via a network to a Wireless LAN or just updated via USB portable drives.

ON THE TENDER.

Standard WASSP installation plus “Explorer” software and hardware options. The Tender will have full multibeam capability with full resolution. Seafloor profiles will be automatically saved for future reference and analysis. Explorer enables the Tender to remotely connect to the Mother Vessel for realtime transmission of position and bathymetric profiles. See your WASSP dealer for full details.

“Builds fantastic 3D profiles of our fishing areas”



1946
ESTABLISHED

2010



WASSP Multibeam Sonar Specifications

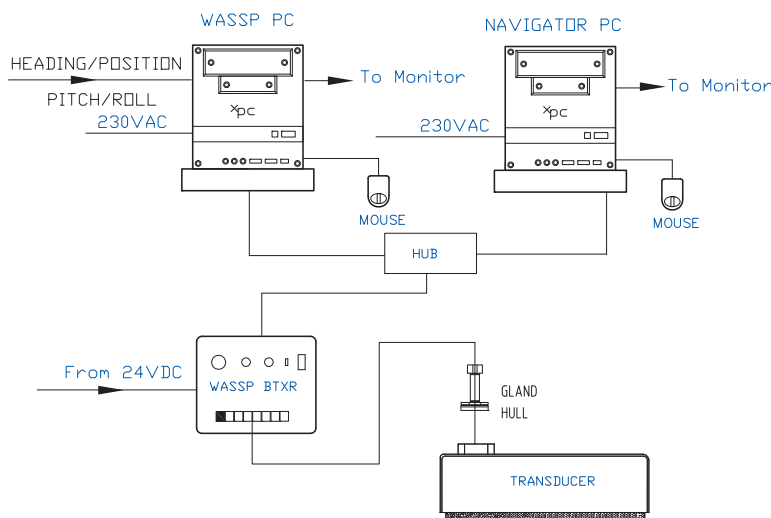

160kHz Transducer

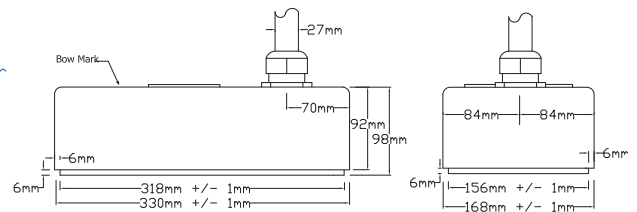

BTxR Dimensions

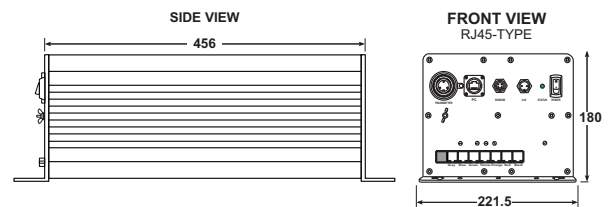

Frequency	160kHz	80 kHz
Sonar Type	Multibeam	Multibeam
Power	40W to 1.2kW	150w to 1.5kw
Transducer Dimensions	330mm(L) x 168mm(W) x 98mm(H)	533mm(L) x 340mm(W) x 98mm(H)
Transducer Weight	15 kg with standard 10m cable	39 kg with 20m cable
Transmit Beam Width (arhtwartships * fore-aft)	120° * 3.5°	120° * 3.5°
Depth Range	1m – 200m	10m – 500m
Beam Forming / Spacing	Digital – 112 equiangular beams from a 120° swath.	Digital – 112 equiangular beams from a 120° swath.
Attitude Correction (Accuracy based on sensor used)	Pitch, Roll, Heave, heading	Pitch, Roll, Heave, heading

*Prices and specifications subject to change without notice.

65 Gaunt Street, Westhaven, Auckland, New Zealand
PO Box 5849, Auckland 1141

Phone: +64 9 373 5595
Fax: +64 9 379 5655
www.enl.co.nz